



STRAPPING MACHINE  
MODEL: M-PAC IV

## M-Pac IV

The semi-automatic strapping machine M-Pac IV is made for manual strapping of various packages. It can be used in many different branches of industry, is distinguished by reliability, easy operation and low maintenance.

### Features:

#### Strap insertion

The strap has to be inserted from the strapcoil into the strap guide in the machine.

#### Operation

After the strapping is placed around the package and is inserted in the machine the strapping cycle will be started automatically. After the strap is sealed, the strap will be ready for the next cycle.

#### Strap tensioning

Stepless adjustable.

#### Flexible application

The M-Pac IV can be used almost anywhere with its 4 wheels and 230V.



1. Main Switch
2. Reset switch
3. Feed switch
4. Feed length dial
5. Tension dial
6. Error indicator lamp

### Technical data:

Package size: min. 100 mm x 30 mm  
(BxH)

Strapping material: Polystrap 5, 6, 9  
12,16 mm

Dimensions: height: 750 - 920 mm  
width: 780 mm  
depth: 543 mm

Strapcoil: core diameter: 200 mm  
outer diameter: 420 mm  
width: 190 mm

Strap tension: max. 392 N

Noise: max. 75 dB(A)

Heating time: approx. 30 -45 sec.

Supply: 230 V, 1 phase 50 Hz, 0,25 kVA

Machine weight: approx. 45 kg

Color: RAL 5003

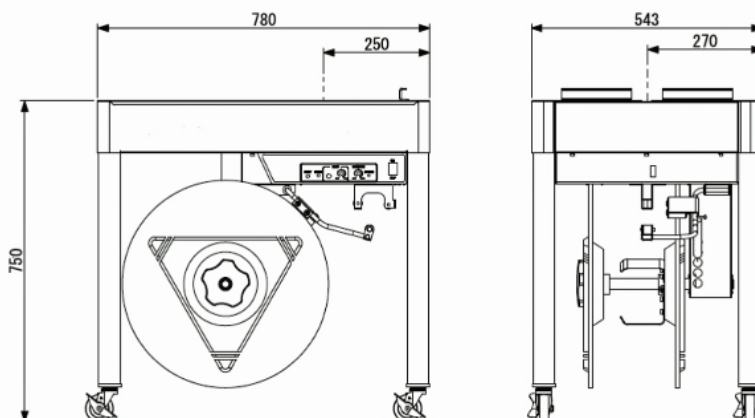

Subject to changes  
Version 06/2012

[WWW.CYKLOP.CO.UK](http://WWW.CYKLOP.CO.UK)

DIRECT CONTACT: +44 1480 216777

Cyklop UK Limited  
Unit 2, Generation Business Park  
Barford Road  
St. Neots, Cambridgeshire, PE19 6YQ  
[info@cyklop.co.uk](mailto:info@cyklop.co.uk)

**CYKLOP**  
INTERNATIONAL

THE  
STRAPPING  
COMPANY

100 YEARS  
1912/2012

